

# Mobile Single Column Lift

INSTALLATION AND OPERATING INSTRUCTIONS

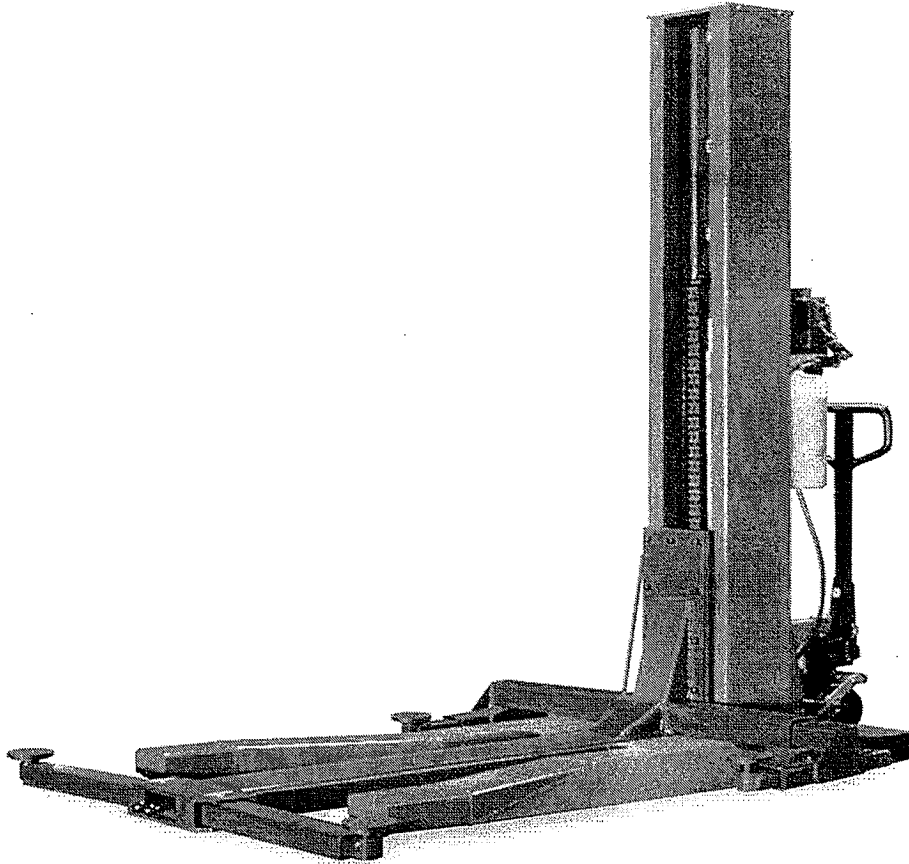

**Important!**

**Be sure to read the operating instructions before operating your lift!**

**Getting Ready**

Make sure you have made all necessary measurements to assure that your lift will fit in your shop / garage and accommodate the car you intend to lift with it. Make sure you have enough clearance at the top, and enough width to allow walking around. And make sure he knows what the circuit requirements are (220 volt, single phase, 30 amp).

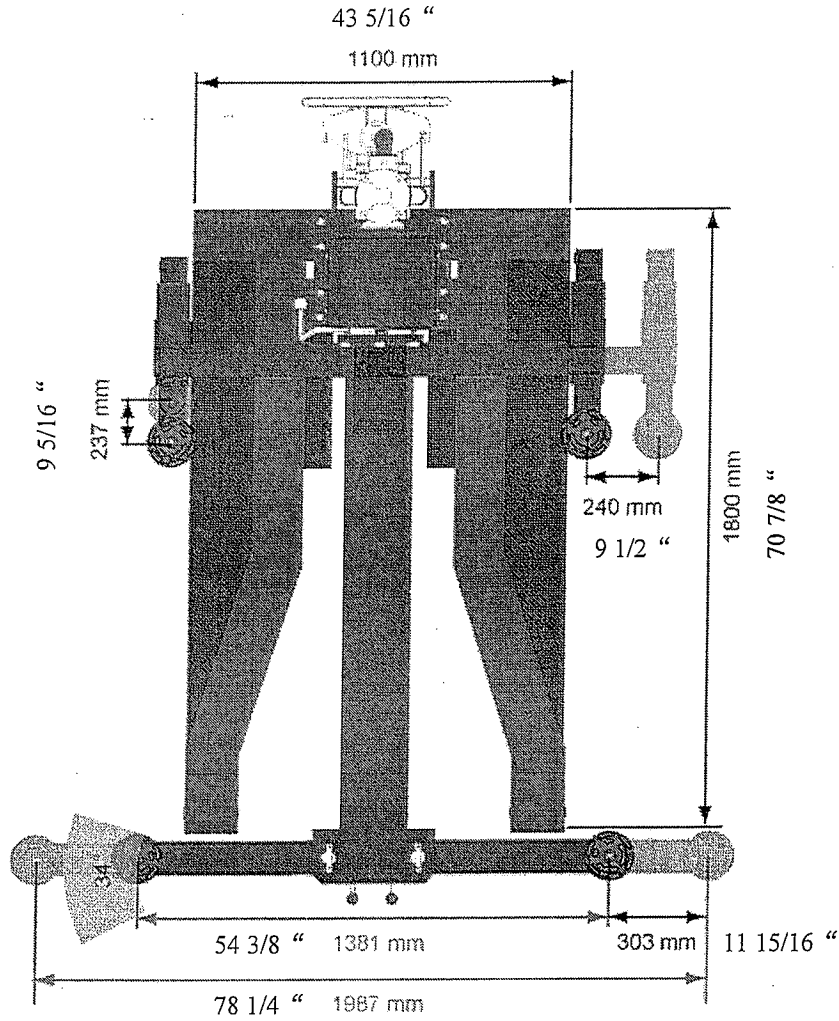

**Fig. 1**

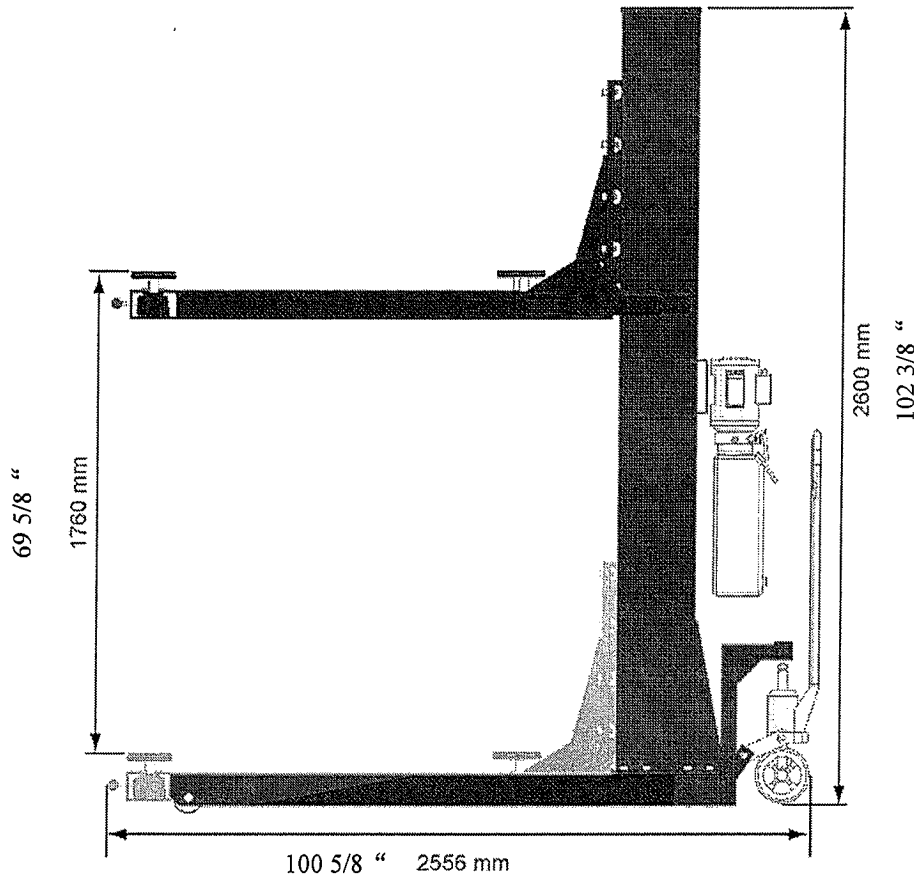

Fig. 2

Make sure you have someone to help you. The pieces to this lift are big, heavy, and cumbersome. The lift column weighs about 320 pounds by itself. Base plate and arms all weigh a couple of hundred pounds apiece. It is possible for two people to install this lift if they have the appropriate lifting and handling equipment, but it is definitely easier and faster if there are several people available to help manhandle the pieces into place. As with any activities involving big heavy materials, safety must be uppermost in your mind. This lift is more difficult to install than some of our other units because of its one-post design, but this very design makes it extremely effective for shop and residential garage use. With proper preparation and installation, you will be very pleased with this lift.

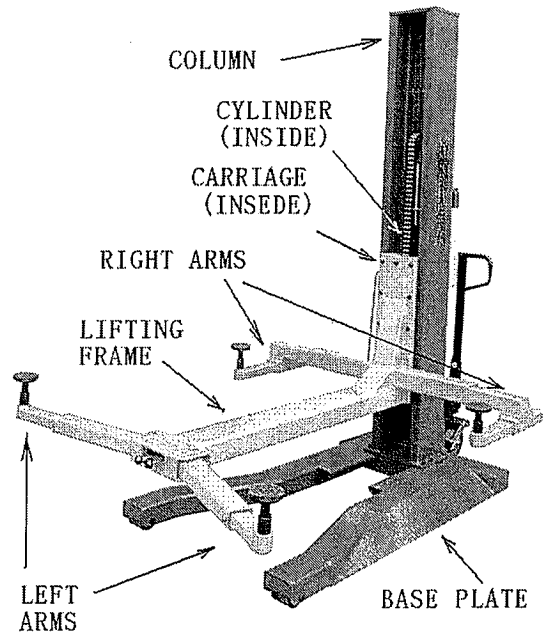
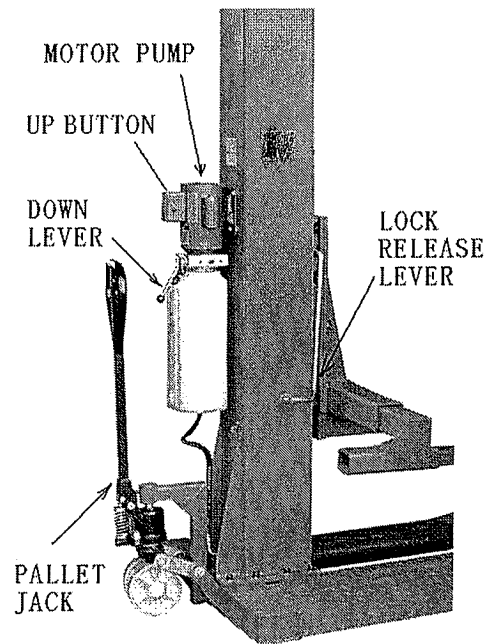

Fig.3A

### Required Tools

1. Fork Lift to unload lift on delivery
2. Fork Lift and/or engine hoist for moving pieces and positioning lift column. You will also need a ten-foot length of 3/8" chain
3. 1 and 5/16" wrench and socket with ratchet
4. 1 and 1/8" socket and extension
5. 1/2" wrench
6. 11/16" wrench
7. Adjustable wrench
8. Small crowbar or large screwdriver for aligning bolt holes
9. Pliers
10. Flat blade screwdriver



**Fig. 3B**

### Receiving and Handling

When you receive your lift, it will come banded to one package, and you will need a forklift to unload it.

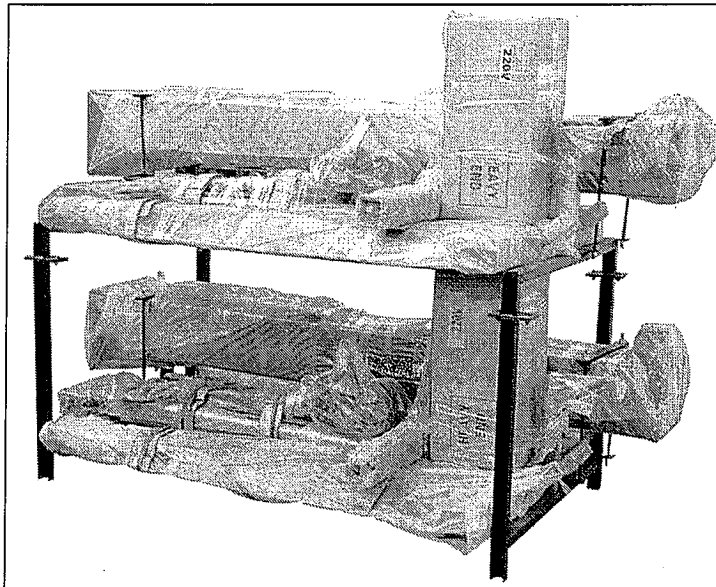

**Fig.4**  
**two lift in one packing**

## Installation

You will need common hand tools that most homeowners have, like a hammer, screwdrivers and pliers, but in addition, you will need some tools that are not common. Each installation is somewhat different, and depends on how much room you have to work around the lift. Here is a chronological sequence of installation steps, with the associated tools.

### **1 Unloading the lift**

You'll need a forklift that can handle about 2000 to 2300 pounds and operate on a smooth surface.

### **2 Un-banding the lift**

The steel bands which secure the lift parts to the pallets are heavy duty. You'll need a pair of metal shears or tin snips to cut the bands. Be very careful when doing this because the bands will tend to fly apart when they are cut, and the heavy lift parts may shift when freed from the bands. Stand to the side of the bands when you cut them, and use gloves when removing the cut bands because they have sharp edges.

### **3. Moving pieces**

You can move the pieces to the garage with the forklift. Some of the smaller pieces can be moved by two or more people carrying them. If you have several people helping, some of the larger pieces can be moved manually.

#### STEP 1

The first step is to take off the board and bracket for shipping. (Fig. 5) Please take out every pieces. Put the base plate on the ground. (Fig. 6)

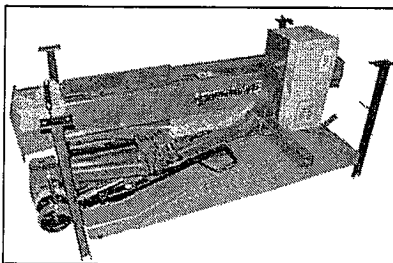

Fig. 5

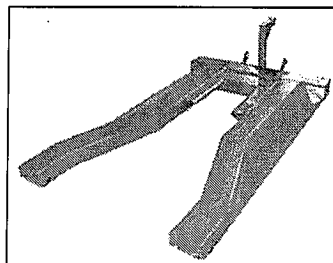

Fig. 6

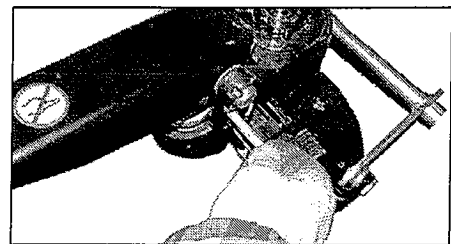

Fig. 7

#### STEP 2

Take out the lock pin on the pallet jack (Fig. 7). Put the steel ball on the top of the jack ram (Fig. 8).

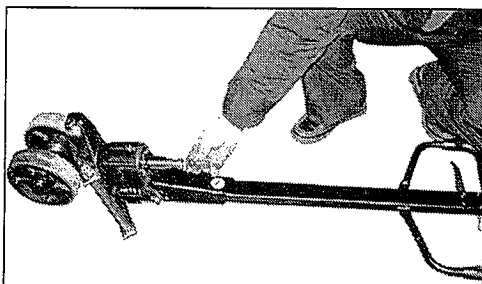

Fig. 8

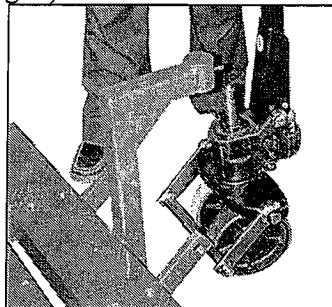

Fig. 9

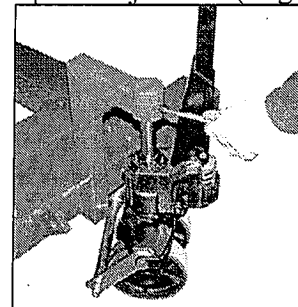

Fig. 10

Insert the ram into the hole of the base plate (Fig. 9). Lock the ram by socket balt (Fig. 10). Adjust the length of the ram (Fig. 11 & 12).

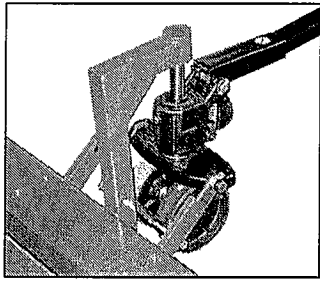

Fig. 11

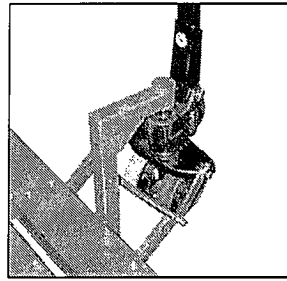

Fig. 12

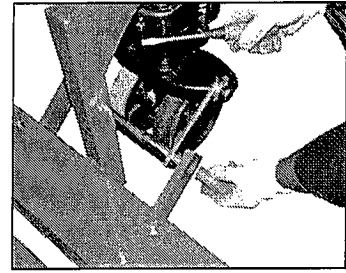

Fig. 13

Put the slot of the bearing into the bracket (Fig. 13) then lock it by bolt (Fig. 14 & 15) Then the base plate with pallet jack is ready (Fig. 16).

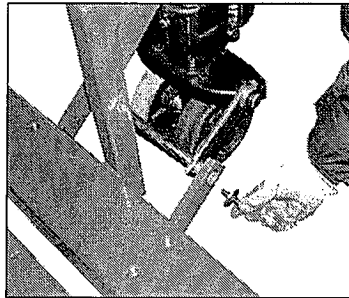

Fig. 14

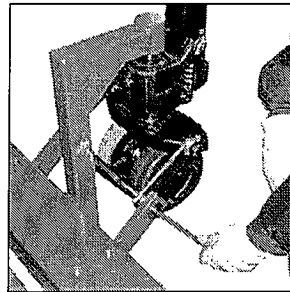

Fig. 15

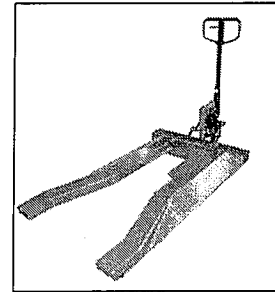

Fig. 16

### STEP 3

Take out the carriage and the lock release handle ( Fig. 17). Insert the end of handle into the bearing and lock it by bolt.( Fig. 18 & 19)

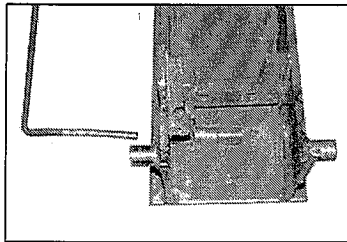

Fig. 17

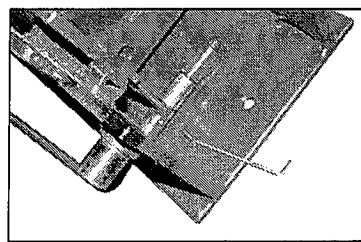

Fig. 18

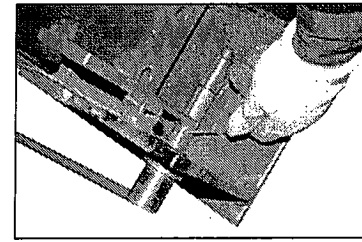

Fig. 19

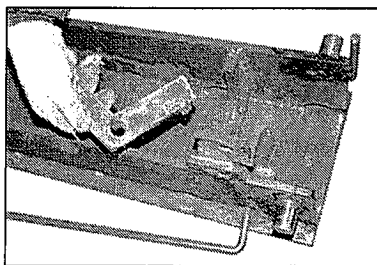

Fig. 20

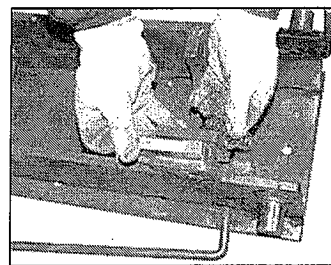

Fig. 21

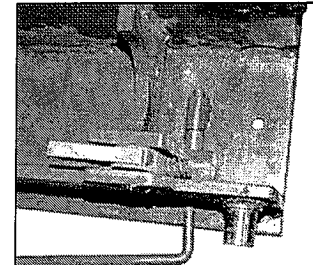

Fig. 22

Assemble the latch lock release handle and spring as in Fig (20—25)

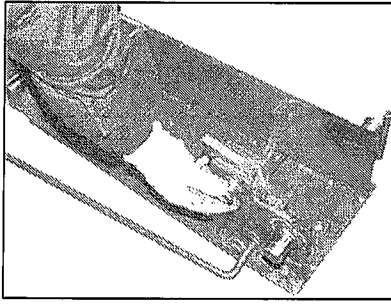

Fig. 23

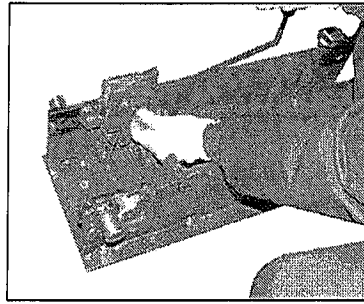

Fig. 24

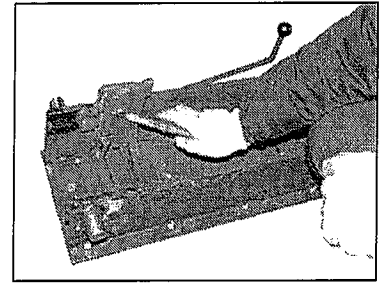

Fig. 25

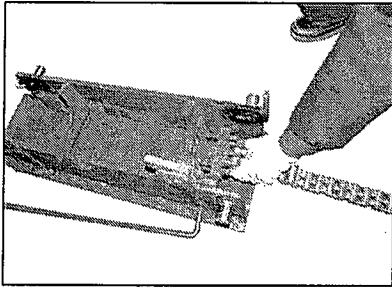

Fig. 26

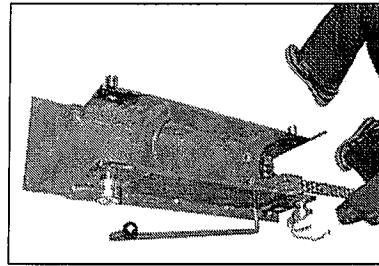

Fig. 27

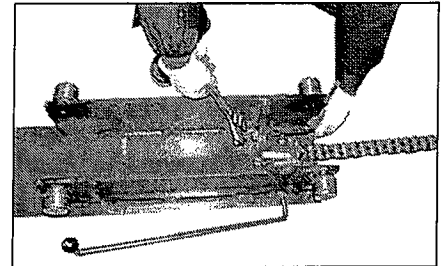

Fig. 28

Fix the chain and the roller to the carriage. ( Fig. 26—29)

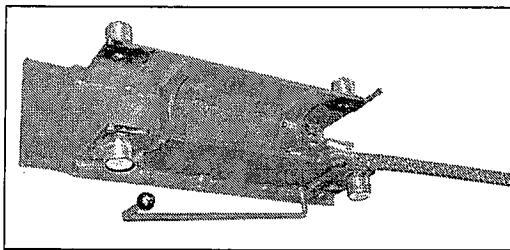

Fig. 29

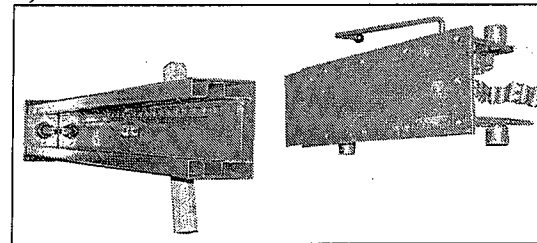

Fig. 30

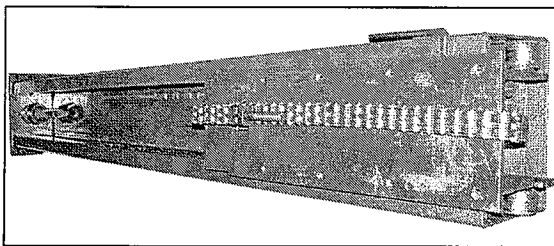

Fig. 31

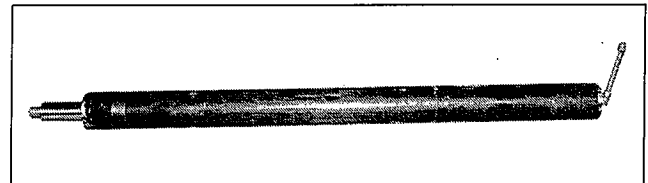

Fig. 32

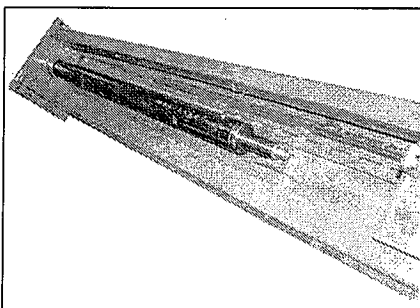

Fig. 33

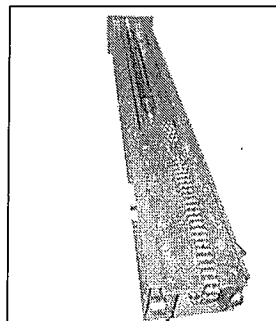

Fig. 34

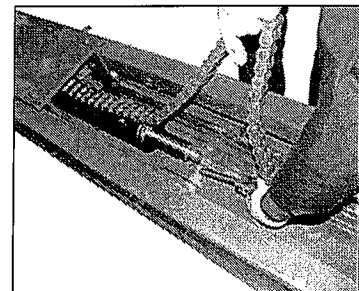

Fig. 35

**STEP 5**

Put the carriage into the column (Fig. 30, 31)

Put the cylinder into the column also (Fig. 32—34), Be careful that the oil tube should be in the hole on the back..

Slide the carriage to the bottom of the column. Fix the another end of the chain to the column. (Fig. 35, 36)

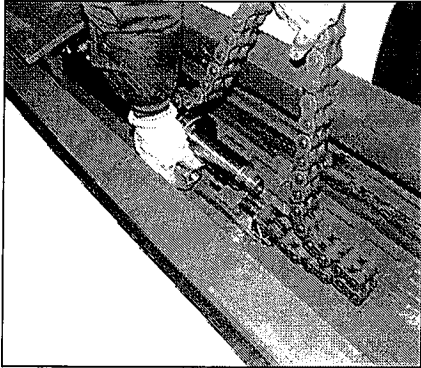

Fig. 36

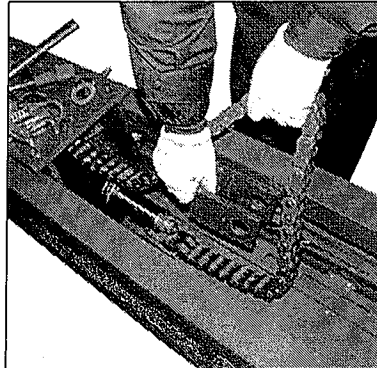

Fig. 37

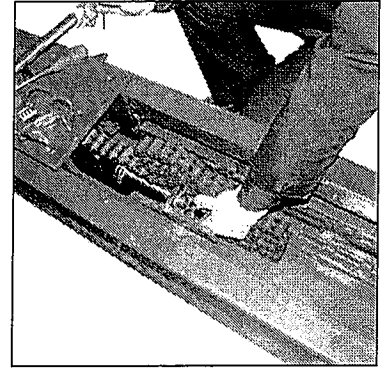

Fig. 38

Assemble the chain roller and bracket on the cylinder head. (Fig. 37—45).

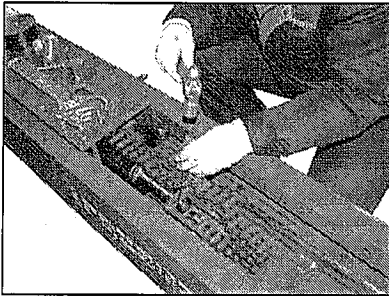

Fig. 39

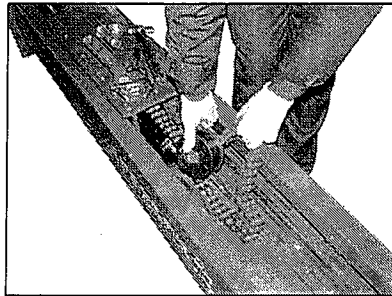

Fig. 40

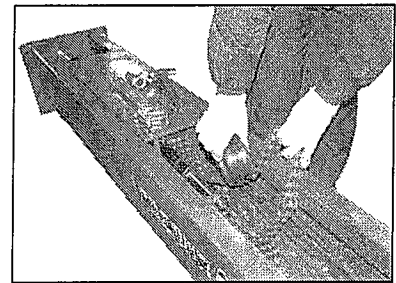

Fig. 41

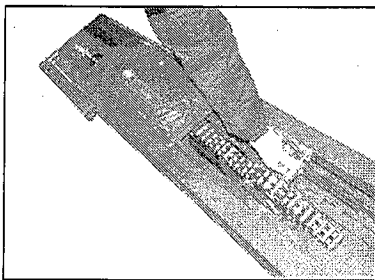

Fig. 42

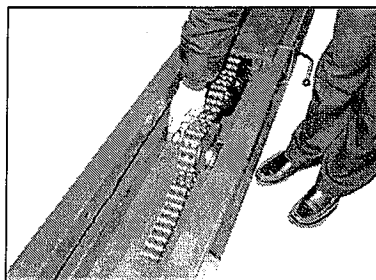

Fig. 43

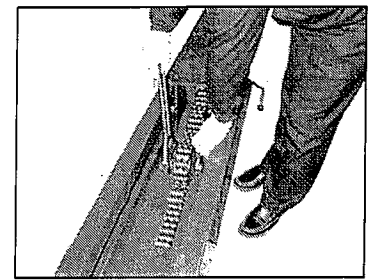

Fig. 44

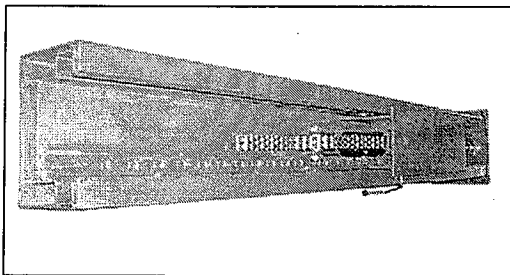

Fig. 45

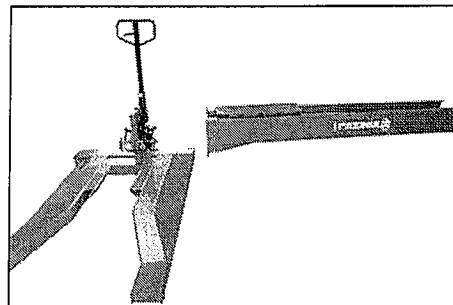

Fig. 46

**STEP 6**

Upright the column and then fix it on the base plate with bolts (Fig. 46—49)



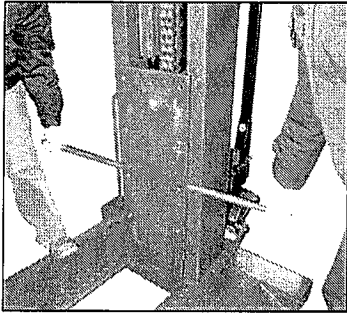

Fig. 47

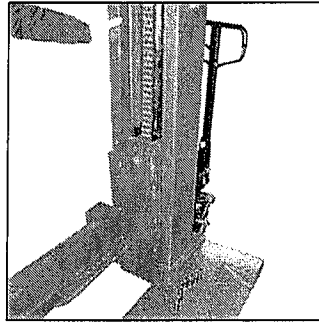

Fig. 48

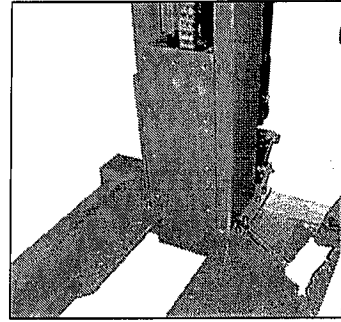

Fig. 49

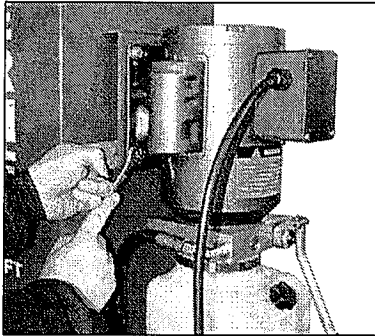

Fig. 50

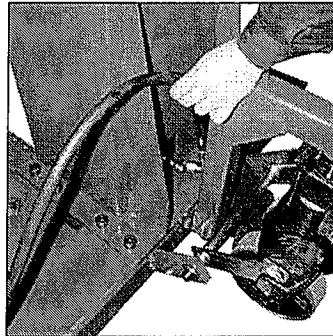

Fig. 51

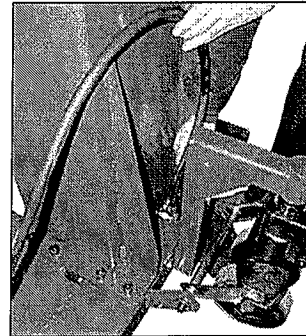

Fig. 52

Put the hydraulic motor pump on the column side with bolts and nus. (Fig 50)

Connect the hose to the cylinder and the motor pump using the hose fitting. (Fig. 51-54)

Now you need to get the correct plug installed on the power cord. Your lift will come with a cord attached to the motor pump, but because there are so many receptacle variations, you will need to install the proper plug on the end of the cord. If you are not sure which plug to use, consult your electrician

Remove the rubber cap from the top of the reservoir. Fill the reservoir with 32 AWS hydraulic oil to near the top

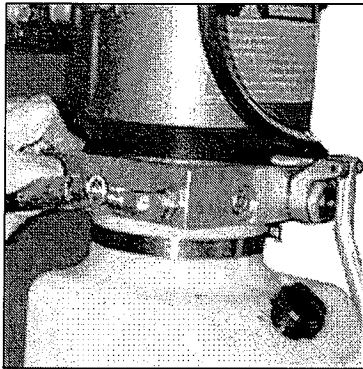

Fig. 53

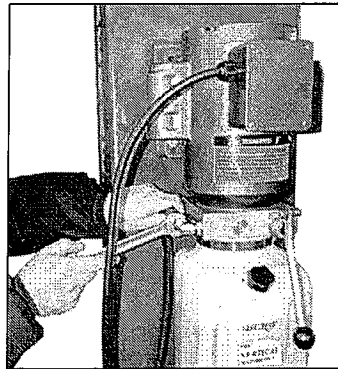

Fig. 54

### STEP 7

Put the lifting frame in front of the base plate. Than fix the frame onto the carriage with bolts. ( Fig. 55—58)

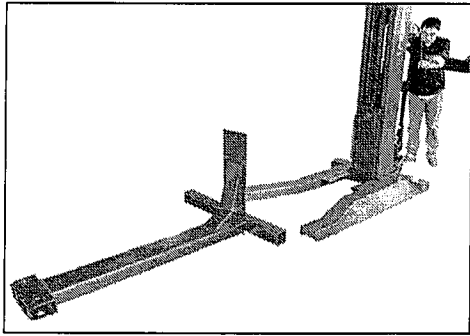

Fig. 55

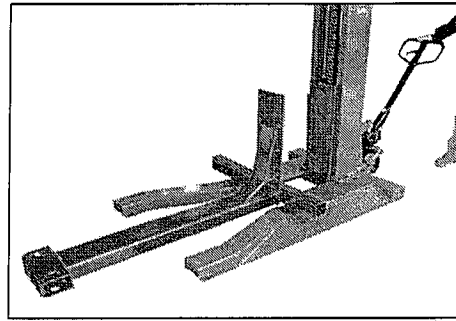

Fig. 56

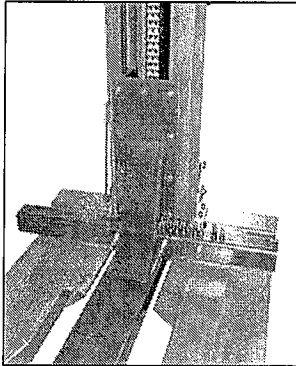

Fig. 57

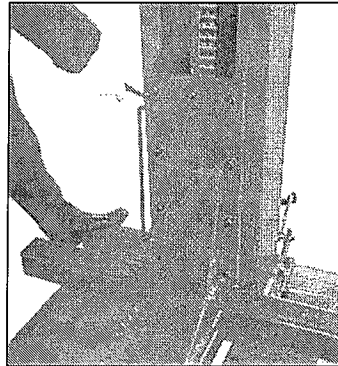

Fig. 58

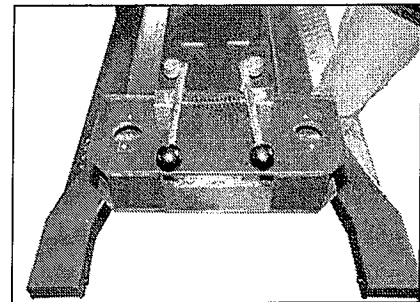

Fig. 59

**STEP 8**

Find out the left arm lock parts ( Fig. 59) Assemble them in the frame end. (Fig. 60-63)

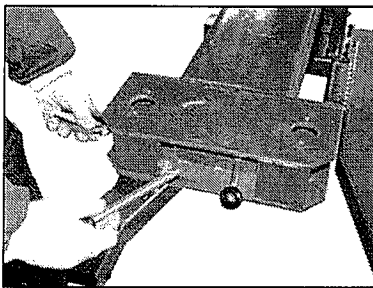

Fig. 60

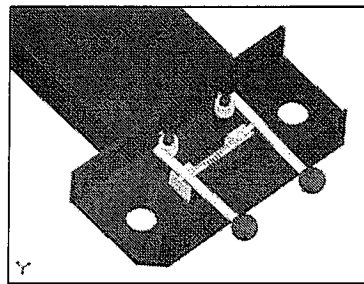

Fig. 61

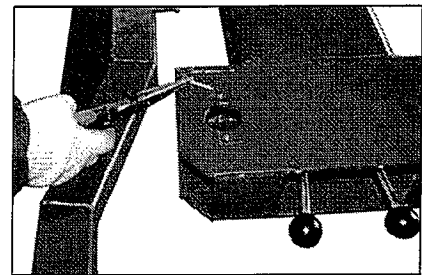

Fig. 62

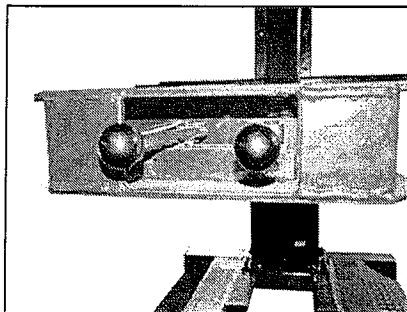

Fig. 63

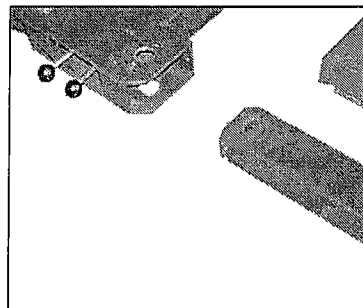

Fig. 64

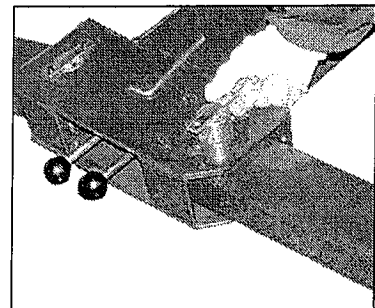

Fig. 65

Assemble the left arms to the frame also. (Fig 65—68)

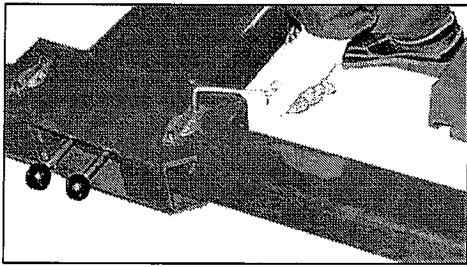

Fig.66

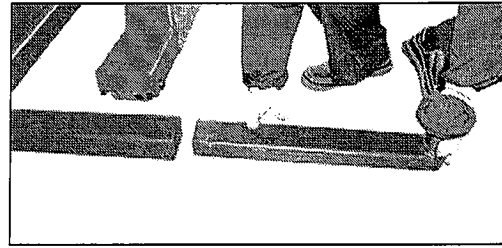

Fig. 67

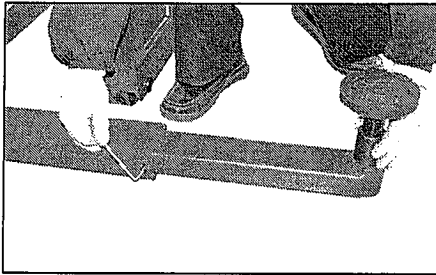

Fig. 68

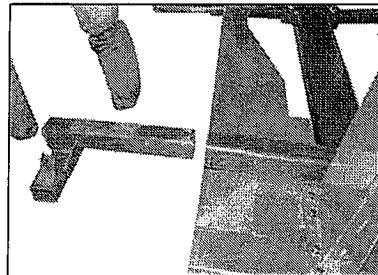

Fig. 69

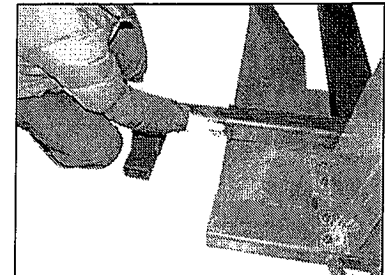

Fig. 70

Put the right arms and extensions to the frame too. ( Fig. 69 – 72)

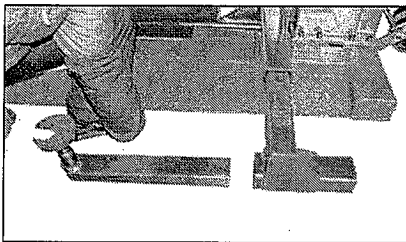

Fig. 71

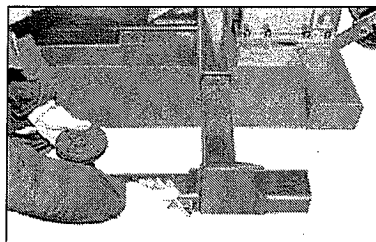

Fig. 72

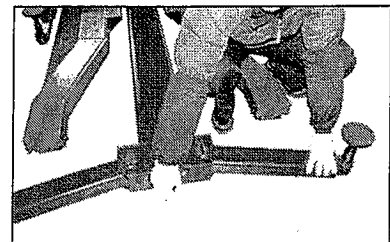

Fig. 73

Again check the lock of the left arms ( Fig.73) Now the lift is ready.

## OPERATING INSTRUCTIONS

The lift is very simple to operate. The black button on the control unit is pushed in and held to activate the switch which turns the electric motor on ( Fig 74) . The motor operates an internal pump that forces hydraulic oil into the lift piston, which extends the roller chain and raises the lift. As the lift rises, an internal safety latch will pass over the steel stops (rectangular blocks which protrude from the back, inside of the lift column), and you will hear “clanks” as it does so. This sound is normal, and indicates that the safety latch is passing over the stops properly. The lift is raised to the desired height by holding the button in while it is rising, and releasing the button when the lift has reached its desired position. To lower the lift, you must depress the red-handled release valve, at the same time as you pull out and hold the safety latch lock release lever ( Fig. 75). The weight of the lift will cause the lift to lower by gravity. No power is required to lower the lift, but the safety latch must be disengaged to allow the lift to lower past the stops. Occasionally the lift may be resting on a stop, which prevents the safety latch from being disengaged. When this happens, simply press the “up” button momentarily, to “bump” the lift upwards slightly, which takes the weight off of the safety latch. Now you can pull the release lever, and again depress the release valve handle to lower the lift. The safety stops do not engage at lower levels, so you do not have to pull the safety latch cable to lower the lift when it is close to the floor. After the

installation is complete, raise the lift about two feet and then lower it. Repeat this process two or three times, and then top off the hydraulic oil reservoir again, if necessary. This assures that hydraulic oil is distributed everywhere in the system that it needs to be.

**NOTE: Only top off the reservoir with the lift in the “down” position. If you fill the reservoir in the “up” position and then lower the lift, there will be too much hydraulic oil in the system, and it will squirt out of the top of the control unit.**

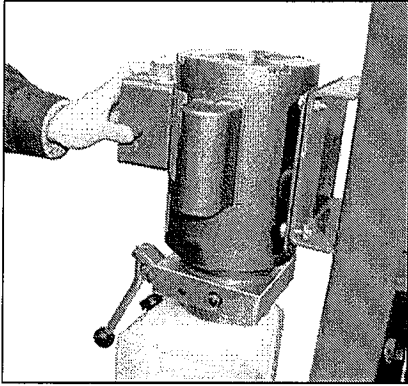

Fig. 74

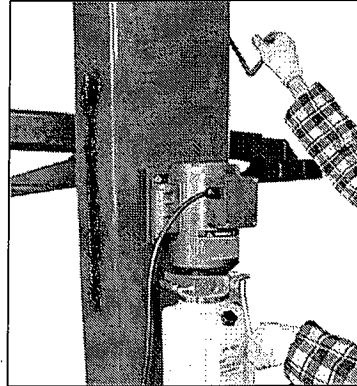

Fig. 75

## **RAISING A VEHICLE**

Drive the vehicle onto the ramps until it is about centered. Set the parking brake. Move out the arms to make the rubber pad under the support position of the vehicle frame. Depress the “up” button to raise the vehicle a little ( Fig. 76). Check again all the arms to make sure everything is in safe. Then lift up the vehicle to desired height. ( Fig. 77)

**BE CAREFUL NOT TO RAISE THE VEHICLE SO HIGH THAT IT STRIKES THE CEILING! MAKE SURE ANTENNAS ARE REMOVED, IF NECESSARY, AND BE AWARE OF ANYTHING THAT PROTRUDES FROM THE CEILING, LIKE LIGHTBULBS, GARAGE DOOR OPENERS OR DOOR TRACKS.**

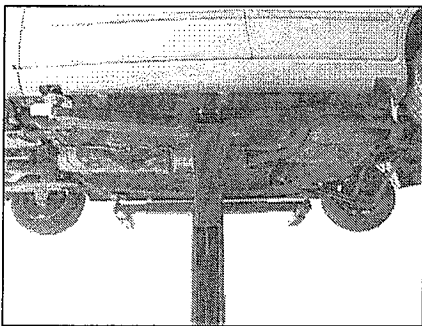

Fig. 76

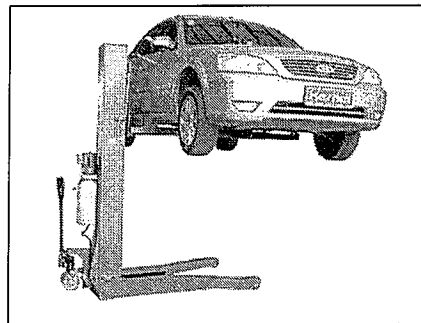
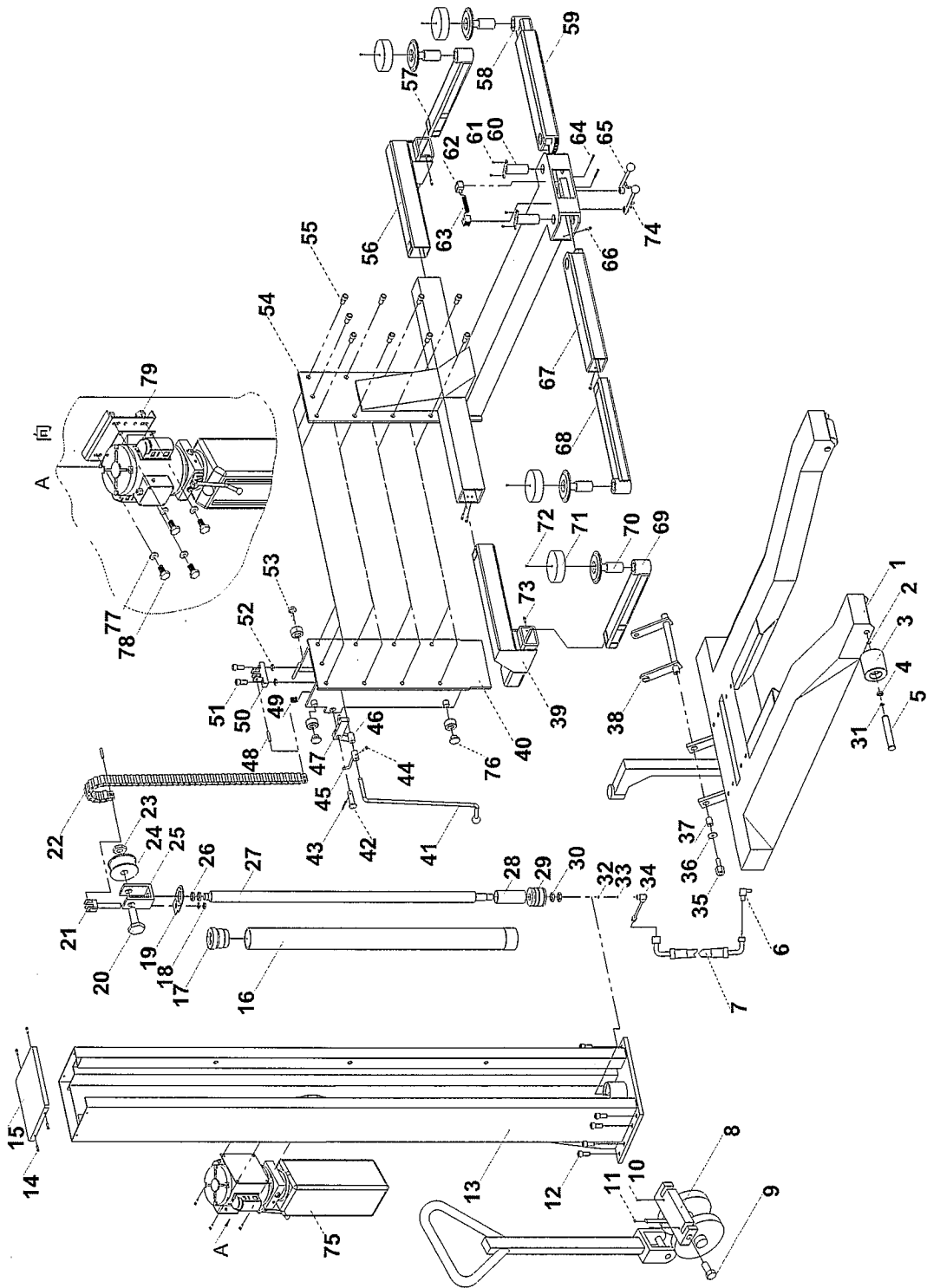

Fig. 77

## **MISCELLANEOUS**

The hydraulic oil should be replaced every two years, and the inside corners of the lift leg should be re-greased with a general-purpose axle grease every year, or so, as it becomes obvious that it needs it.

# MOBILE SINGLE POST LIFT 167251 PARTS DRAWING



## PARTS CODE LIST

ITEM	CODE	DESCRIPTION	QTY	NOTE
1	1672510001	Base plate	1	
2	1672510002	Elastic washer	4	
3	1672510003	Pulley	2	
4	1672510004	Bearing	4	
5	1672510005	Spindle	2	
6	1672510006	Direct fitting	1	
7	1672510007	Hose	1	
8	1672510008	Dolly	1	
9	1672510009	Pin	2	
10	1672510010	Elastic pin	2	
11	1672510011	Ball bearing	1	
12	1672510012	Bolt	8	M16*40
13	1672510013	Column	1	
14	1672510014	Bolt	4	M6*20
15	1672510015	Cover	1	
16	1672510016	Hydraulic cylinder	1	
17	1672510017	Guiding ring	1	
18	1672510018	Nut	2	
19	1672510019	Guiding ring ass'y	1	
20	1672510020	Spindle	1	
21	1672510021	Position bar	1	
22	1672510022	Chain ass'y	1	
23	1672510023	Nut	1	M24
24	1672510024	Wheel	1	
25	1672510025	Wheel basement	1	
26	1672510026	Nut	2	M27*1.5
27	1672510027	Piston shaft	1	
28	1672510028	Bushing	1	
29	1672510029	Piston	1	
30	1672510030	Nut	2	M24*1.5
31	1672510031	Bushing	4	
32	1672510032	Elastic washer	1	
33	1672510033	Washer	1	
34	1672510034	Connection hose	1	
35	1672510035	Bolt	2	M12*20
36	1672510036	Flat washer	2	
37	1672510037	Bushing	2	
38	1672510038	Support	1	
39	1672510039	Streight beam(Left)	1	
40	1672510040	Carriage	1	
41	1672510041	Safety handle	1	
42	1672510042	Spindle	1	
43	1672510043	Spilt washer	1	

ITEM	CODE	DESCRIPTION	QTY	NOTE
44	1672510044	Bolt	1	M6*30
45	1672510045	Swing pole	1	
46	1672510046	Bushing	1	
47	1672510047	Swing arm	1	
48	1672510048	Chain spindle	2	
49	1672510049	Spring	1	
50	1672510050	Position bar	1	
51	1672510051	Bolt	2	M16*50
52	1672510052	Nut	2	M16
53	1672510053	Nylon wheel	4	
54	1672510054	Hoist ass'y	1	
55	1672510055	Bolt	9	M16*35
56	1672510056	Streight beam(Right)	1	
57	1672510057	Moving beam(Right)	1	
58	1672510058	Right Arm	1	
59	1672510059	Support	1	
60	1672510060	Pin	2	
61	1672510061	Screw	4	M6*10
62	1672510062	Cog-wheel	2	
63	1672510063	Spring	1	
64	1672510064	Elastic pin	2	
65	1672510065	Handle(Right)	1	
66	1672510066	Bolt	2	M6*25
67	1672510067	Support	1	
68	1672510068	Left Arm	1	
69	1672510069	Moving beam(Left)	1	
70	1672510070	Bolt ass'y	4	
71	1672510071	Rubber washer	4	
72	1672510072	Screw	4	M10*10
73	1672510073	Bolt	8	M8*12
74	1672510074	Handle	1	
75	1672510075	Power Unit	1	
76	1672510076	Slide Block	4	
77	1672510077	Flat washer	8	
78	1672510078	Bolt	4	
79	1672510079	Nut	4	